

RoHS
Compliant

SYMBOL	REVISION	APPROVAL	DATE

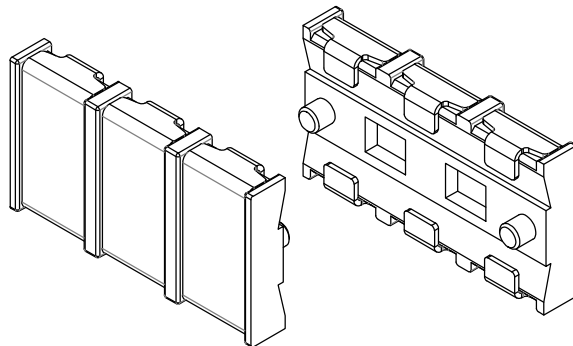
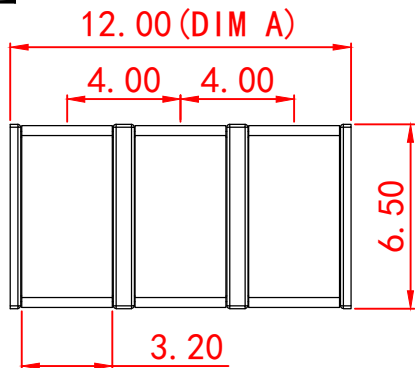

SPECIFICATIONS

- ELECTRICAL CHARACTERISTICS:
 - RATING: DC 12V 3A
 - CONTACT RESISTANCE: 50mΩ MAX (INITIAL)
 - DIELECTRIC WITHSTANDING VOLTAGE: 500V AC FOR ONE MINUTE
 - INSULATION RESISTANCE: 500MΩ MIN, MEASURED BY 500V DC
- FORCE: 0.6mm CONTACT TRAVEL: 600gf Max.
- LIFE TEST: MECHANICAL LIFE TEST 5,000 CYCLES.
- TEMPERATURE RISE : 30° C MAX

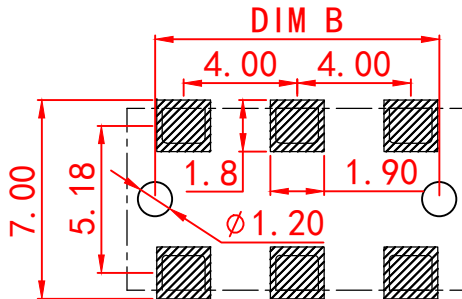
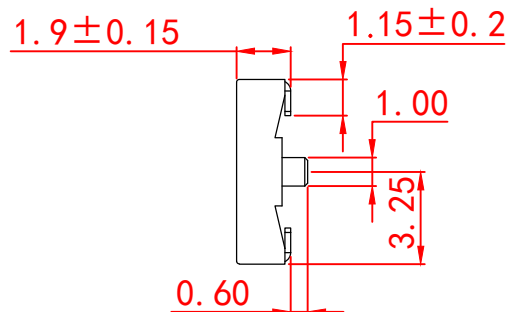
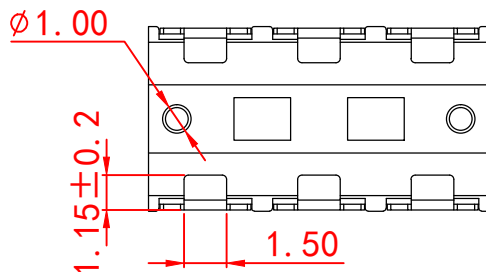
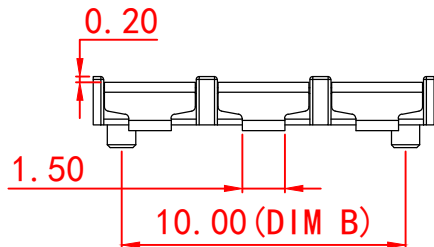

RECOMMENDED PCB LAYOUT
TOP VIEW (. XX ± 0.05)

型号规格	DIM A	DIM B
ND-2P-4.0PH-1.9HD母座	8.0	6.0
ND-3P-4.0PH-1.9HD母座	12.0	10.0
ND-4P-4.0PH-1.9HD母座	16.0	14.0
ND-5P-4.0PH-1.9HD母座	20.0	18.0
ND-6P-4.0PH-1.9HD母座	24.0	22.0

NO.	PARTS	MATERIAL	QTY.	FINISHING
2	HOUSING	LCP	1	GRAY
1	CONTACT TERMINAL	PHOSPHOR BRONZE	3	Au PLATED

广东诺德电子科技有限公司

COPYRIGHT RESERVED, PLEASE DO NOT COPY.

PART NAME	CONNECTOR	DRAWING	Y. C. Zhang	DWG. No.
PART NO.	ND-4.0PH-1.9HD母座系列	CHECK	G. C. Chen	REV. A1
UNIT: mm	TOLERANCE	ANGLE	APPROVAL	DATE
	OTHERWISE	SCALE	3:1	PAGE

06-06-2018
1 OF 1